

汽车继电器

TRV5

- Open or sealed cover available
- 40A continuous rating 80°C
- Conform to RoHS,ELV directive



■ ORDERING CODE 订购代码

TRV5 <u>L</u> — <u>H</u> — <u>F</u> / 12VDC 1 2 3 4 5					
1. Relay Model 继电器型号	2. Coil Power 线圈功率 L=1.44W		3. 触点转换形式 H: Form A	4. F: 外壳有安装位 Nil: 外壳无安装位	5. Coil Nominal Voltage 线圈额定电压 6,12,24VDC

■ COIL DATA 线圈参数 (at 20°C)

Nominal Voltage 额定电压(VDC)	6	12	24	1.44W
Coil Resistance 线圈阻值($\Omega \pm 10\%$)	25	100	400	
Rated Current 额定电流(mA)	240	120	60	
Max Operate Voltage 最大吸合电压(VDC)	3.9	7.8	15.6	
Min Release Voltage 最小释放电压(VDC)	0.3	0.6	1.2	
Max Applicable Voltage 最大过载电压	70°C时额定电压的130%，23°C时额定电压的170%			

■ CONTACT DATA 触点参数

Contact Form 触点形式	1H
Contact Material 触点材料	Silver Alloy
Load 负载	Resistive load(COS Φ =1)
Contact Ratings 触点负载	30A 14VDC 15A 28VDC
Max Switching Voltage 最大转换电压	28VDC
Max Switching Current 最大转换电流	30A
Max Switching Power 最大转换功率	420W
Contact Resistance 接触电阻	100m Ω Max at 6VDC 1A
Life Expectancy 寿命	Electrical 电气寿命: 100,000 Operations(at30Operations/minute)
	Mechanical 机械寿命: 10,000,000 Operations(at300Operations/minute)

■ CHARACTERISTICS DATA 性能参数

Insulation Resistance 绝缘阻值	100M Ω Min at 500VDC
Dielectric Strength Between Open Contacts 触点间耐压	500VAC(for one minute)
Between Contacts and coil 触点与线圈间耐压	500VAC(for one minute)
Operate Time 吸合时间	15ms
Release Time 释放时间	8ms
Temperature Range 环境温度	-40°C to +85°C

Shock Resistance冲击	Operating Extremes动作极限: 10G
	Damage Limits破坏极限: 100G
Vibration Resistance振动	10-55Hz, 1.5mm
Max. switching frequency最大转换频率	Mechanical: 18,000operations/hr Electrical: 1,800operations/hr
Humidity湿度	45-85%
Weight重量	Approx 28g

ENGINEERING DATA 设计参数

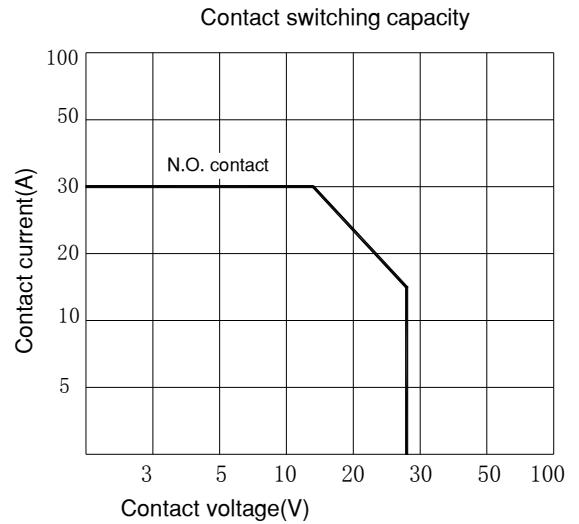
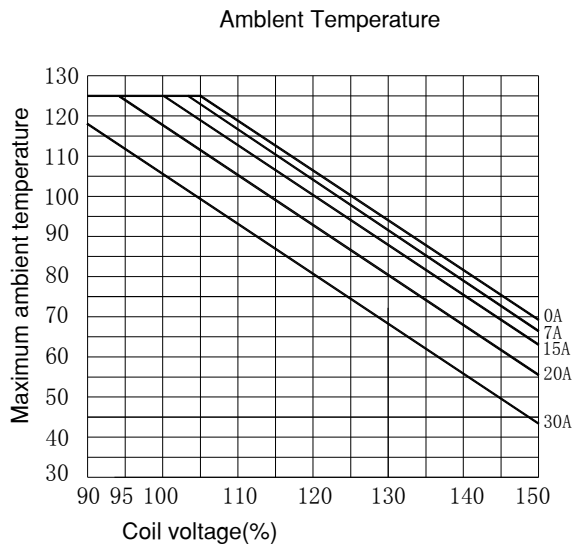

OVERALL AND MOUNTING DIMENSIONS 安装图

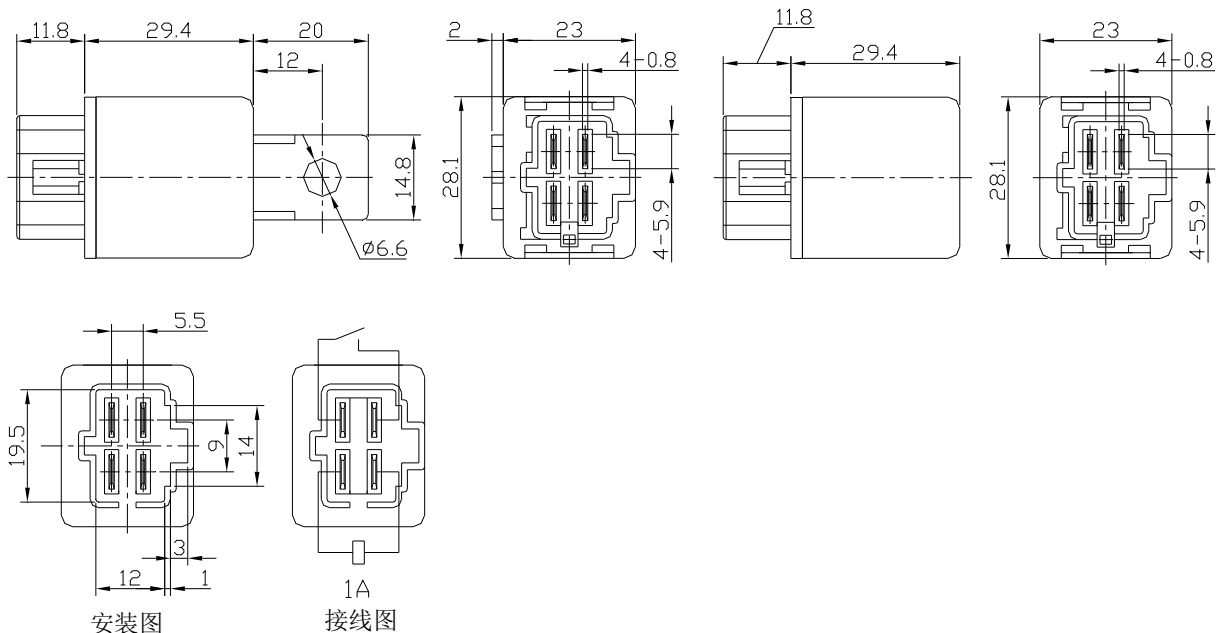

备注: 1) 产品部分外形尺寸中未注尺寸公差: 当外形尺寸 $\leq 1\text{mm}$ 时, 公差为 $\pm 0.2\text{mm}$; 当外形尺寸在 $1\sim 5\text{mm}$ 时, 公差为 $\pm 0.3\text{mm}$; 当外形尺寸 $> 5\text{mm}$ 时, 公差为 $\pm 0.4\text{mm}$ 。

2) 安装孔尺寸中未注尺寸公差均为 $\pm 0.1\text{mm}$ 。

声明:

本产品规格书仅供客户使用时参考, 如有更改, 恕不另行通知。